

AC4S35HM

STANDARD MATERIALS AND CONSTRUCTION

FRAME: .081" thk. (nominal) extruded aluminum 6063-T52/T6 alloy.

BLADES: Stationary blades are made from .081" thk. (nominal) extruded aluminum 6063-T52/T6 alloy. Adjustable Blades are made from .125" thk. (nominal) extruded aluminum 6063-T52/T6 alloy. Blades approximately 3 1/2" on centers.

LOUVER FACE: Full width sill with head and blades contained within jambs.

LINKAGE: Extruded aluminum, concealed in the channel out of the airstream. The pivots, which rotate in Celcon bearings, are .50" dia. plated and machined steel. The pivot is locked to the 3/16" dia. aluminum linkage rod by a 1/4 - 20 set screw with epoxy locking patch.

AXLES: .50" dia. aluminum "Pin-Lock" extrusion.

SEALS: Extruded silicone rubber seals at blade edge. Foam on bottom blade. Stainless steel at jambs.

SCREEN: (When indicated, in a removable frame)
1/2" flattened aluminum, .051" thk.,

-or- Insect screen 1 5/16" aluminum mesh, .011" dia.,

-or- 1/2" sq. mesh intermediate double crimped aluminum wire, .063" dia.

FINISH: Mill

ACTUATOR: 120 VAC spring return normally closed.
133 in.-lbs. torque.

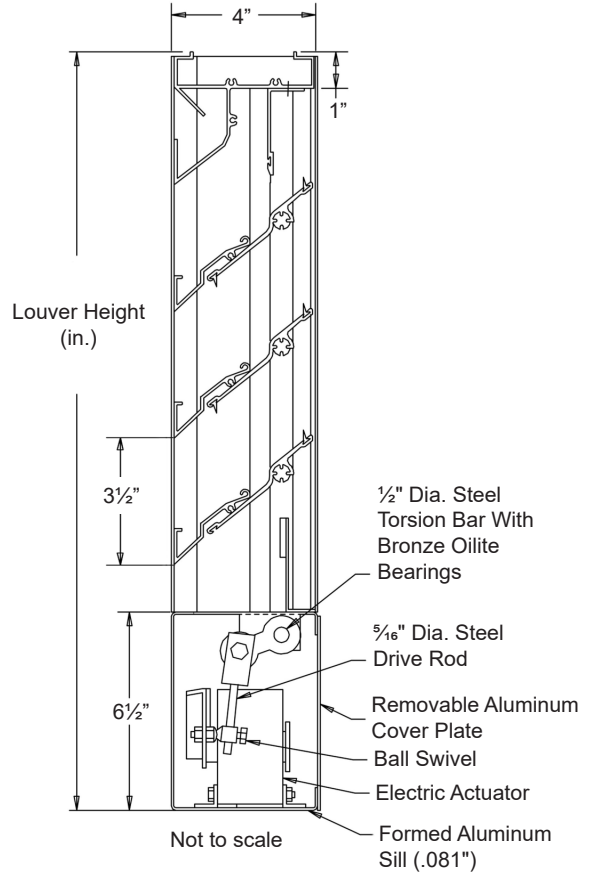

OPTIONS

Finishes - Enamels, Epoxies, etc.

Other screens available.

Actuators - Electric, Pneumatic, Manual, etc.

NOTES

1. Nominal deductions will be made to the opening size given.

2. Approximate shipping weight is 5.5 lbs./sq.ft.

LOUVER SIZES

Min Panel	Max Single Panel
12"W x 16"H	48"W x 96"H

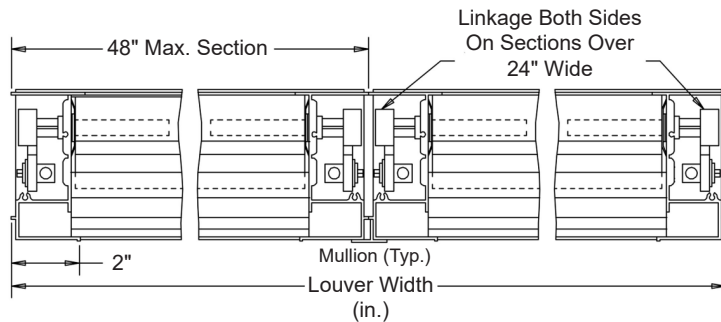

In the interest of product development, Airline Louvers reserves the right to make changes without notice.

										
Item #	Qty	Width	Height	Width	Height	Mullion	Type	Location		
		Opening Size		Louver Size			Screens		Job:	
Arch. / Eng. :						EDR:		ECN:		Job:
Contractor:										
Project:						Date:		DWN:		DWG: